

Clausing MA Series Geared Head Heavy-Duty Large Swing Lathes



Shown with optional Chuck

The Clausing MA series large swing geared head engine lathes are engineered to allow the accurate and efficient machining of large components. A wide range of optional accessories make these machines suitable for most industrial applications, including job shops, oil field, power utilities and ship building.

Machine Standard Features:

- 12 Geared Head Spindle Speeds allow optimum cutting speed for a wide range of machining applications. Speed range 12 to 1000 rpm.
- 15 Hp Spindle Motor for exceptional machining power. Optional 20 Hp
- All gears are made from chromium molybdenum steel treated with cementation and precision ground for long-life and dependability.
- One-piece cast iron bed from the ways to floor provides a solid foundation to ensure maximum stability and rigidity under heavy machining operations.
- 18" Bed Width, Hardened and Ground, support the saddle and carriage assembly allowing superior positioning and repeatability accuracy.
- Turcite 'B' is fitted between saddle and bed to greatly reduce friction and stick-slip for smooth operation and superior surface finishes. The low friction Turcite 'B' also minimizes bed wear and extends the life of the machine.
- Immersing Style Lead Screw reduces abrasion.
- 4-way Rapid Traverse for positioning and set up.
- 4-way Power Feed for longitudinal, cross and compound feeds.
- Tailstock with 4.18" manual positioning for ease of setup and operation.
- 4.1" Spindle Bore supported with taper spindle bearings provides outstanding spindle performance and load carrying capabilities. Optional spindle bores available.
- Coolant system for tool life and part cooling.
- Automatic lubrication system to all guideways.
- Guarding powder coated for durability.
- Emergency brake pedal for safe operation.



Providing Solutions.

Phone: 916-638-7718 Fax: 916-638-2450

www.scottmachinery.com

4700 Lang Ave, Suite D, McClellan, CA 95652

Standard Equipment:

- Hardened and ground bed ways
- Hardened and ground gears
- Chuck guard with limit switch
- 15 Hp motor with inverter drive
- Geared Head spindle speeds, 12-1000 rpm
- 11" Capacity Steady Rest
- Follower Rest
- 4-way Rapid Traverse
- 4-way Power Feed
- 4-way, 8-position Tool Post
- 1.75" Lead screw
- Lead screw cover
- Coolant system
- Automatic lubrication system
- Thread dial
- Manual tailstock w/ manual movement and anti slip lock
- Lockable main switch
- Halogen work light
- Leveling screws and pads
- Tools, tool box, operation manual

Dimensions, Center Distance and Weight:

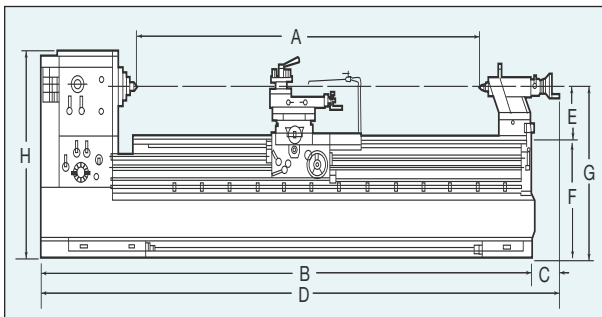

| Model | E | F | G | H |
|-------|----------------|---------------|-----------------|----------------|
| MA26 | 13.38" (340mm) | 29.9" (760mm) | 43.30" (1100mm) | 55.1" (1400mm) |
| MA30 | 15.35" (390mm) | 29.9" (760mm) | 45.27" (1150mm) | 57.1" (1450mm) |

| Model | Width | Center A | B | C | D | Net Weight | Gross Weight |
|------------|----------------|---------------|---------------|--------------|---------------|-----------------------|-----------------------|
| MA26/3079 | 48.8" (1240mm) | 79" (2000mm) | 148" (3750mm) | 5.9" (150mm) | 154" (3900mm) | 8,598 lbs. (3900kgs) | 9,149 lbs. (4150kgs) |
| MA26/30118 | 48.8" (1240mm) | 118" (3000mm) | 187" (4750mm) | 5.9" (150mm) | 193" (4900mm) | 9,921 lbs. (4500kgs) | 10,692 lbs. (4850kgs) |
| MA26/30157 | 48.8" (1240mm) | 157" (4000mm) | 226" (5750mm) | 5.9" (150mm) | 232" (5900mm) | 11,243 lbs (5100kgs) | 12,345 lbs. (5600kgs) |
| MA26/30197 | 48.8" (1240mm) | 196" (5000mm) | 266" (6750mm) | 5.9" (150mm) | 272" (6900mm) | 13,889 lbs. (6300kgs) | 15,432 lbs. (7000kgs) |
| MA26/30236 | 48.8" (1240mm) | 236" (6000mm) | 305" (7750mm) | 5.9" (150mm) | 311" (7900mm) | 15,432 lbs. (7000kgs) | 16,975 lbs. (7700kgs) |
| MA26/30275 | 48.8" (1240mm) | 275" (7000mm) | 345" (8750mm) | 5.9" (150mm) | 350" (8900mm) | 16,975 lbs. (7700kgs) | 18,519 lbs. (8400kgs) |
| MA26/30315 | 48.8" (1240mm) | 315" (8000mm) | 384" (9750mm) | 5.9" (150mm) | 390" (9900mm) | 18,519 lbs. (8400kgs) | 20,282 lbs. (9200kgs) |

Specifications:

| Model | MA26 | MA30 |
|-----------------------------------|-----------------------|-----------------------|
| Capacity | | |
| Swing over bed | 26.7" (680mm) | 30.7" (780mm) |
| Swing over cross slide | 17.32" (440mm) | 21.25" (540mm) |
| Swing in gap | 38.12" (970mm) | 42.12" (1070mm) |
| Gap (in front of faceplate) | 19" (482mm) | 19" (482mm) |
| Headstock | | |
| Spindle nose | A2-11 | A2-11 |
| Spindle bore | 4.13" (105mm) | 4.13" (105mm) |
| Spindle taper | | |
| Headstock | Geared Head | Geared Head |
| No. spindle speeds | 12 | 12 |
| Spindle speed (rpm) | 12-1000* | 12-1000* |
| Min. spindle speed for full power | 45 rpm | 45 rpm |
| Construction | | |
| Bed type | One Piece | One Piece |
| Bed width | 18" (458mm) | 18" (458mm) |
| Bed height over bed | 13.38" (340mm) | 15.35" (390mm) |
| Cross slide travel | 15.35" (390mm) | 15.38" (390mm) |
| Compound slide travel | 9.5" (240mm) | 9.5" (240mm) |
| Leadscrew diameter | 1.77" (45mm) | 1.77" (45mm) |
| Thread and Feed Box | | |
| No. of longitudinal feeds | 28 | 28 |
| Range (in) | 0.0019-0.027 in/rev | 0.0019-0.027 in/rev |
| (mm) | 0.05-0.7 mm/rev | 0.05-0.7 mm/rev |
| No. of cross feeds | 28 | 28 |
| Range (in) | 0.00019-0.1.38 in/rev | 0.00019-0.1.38 in/rev |
| (mm) | 0.025-0.35 mm/rev | 0.025-0.35 mm/rev |
| No. of inch threads | 36 | 36 |
| Range | 2-28 TPI | 2-28 TPI |
| No. of metric threads | 65 | 65 |
| Range | 0.8-14 mm | 0.8-14 mm |
| No. of modular thread | 22 | 22 |
| Range | 0.5-7 Mod | 0.5-7 Mod |
| No. of diametral pitch threads | 36 | 36 |
| Range | 4-56 DP | 4-56 DP |
| Tailstock | | |
| Quill diameter | 8.26" (210mm) | 8.26" (210mm) |
| Quill travel | 4.13" (105mm) | 4.13" (105mm) |
| Center taper | 6MT | 6MT |
| Motors | | |
| Spindle motor | 15 Hp (11Kw) | 15 Hp (11Kw) |
| Rapid feed motor | 1/4 Hp (.19Kw) | 1/4 Hp (.19Kw) |
| Pump motor | 1/8 Hp (.09Kw) | 1/8 Hp (.09Kw) |

(Specifications subject to change without notification)

*Spindles Speeds (rpm): 12, 20, 29, 40, 55, 85, 120, 175, 300, 445, 650, 1000