



Clausing Radial Drills Model: CL1230H

Features and Standard Equipment:

- High-quality cast-iron arm with heat-treated and ground slides for smooth and accurate head positioning
- The bearing bracket for gear-box is fitted with standard bearings to fit arm slide for smooth gear-box operation
- High speed gears are made of Nickel-Chrome Steel and are heat-treated and ground for durability
- Powerful 3 Hp, 2-speed, heavy-duty spindle drive motor
- Overload protection device
- The main spindle is balanced by an adjustable block
- Coolant system
- Low volt and overload protection
- Equipped with hydraulic clamping. With a push of a button you can have arm unclamped then move vertically, or stop then clamp automatically
- CSA Electrics Standard ● Tool kit and manuals

Specifications:

| Model | CL1230H |
|--|------------------------------|
| Working Area: | |
| Column Sleeve Dia. (E) | 11.81" (300mm) |
| Column Face to Spindle Center Maximum (D+C) | 46.1" (1170mm) |
| Minimum (D) | 13.4" (340mm) |
| Spindle Head Travel (C) | 35.0" (890mm) |
| Base Surface to Spindle End Maximum (A) | 53.9" (1370mm) |
| Minimum (B) | 19.3" (490mm) |
| Arm Vertical Travel (A-B) | 24.8" (630mm) |
| Arm Rotation (Right & Left) | 180° |
| Baseplate Working Surface | 48" x 29.1" (1219 x 739mm) |
| Box Table Area | |
| Length (L) | 25.0" (635mm) |
| Width (K) | 24.5" (520mm) |
| Height (H) | 16.3" (415mm) |
| Base Dimensions | |
| Floor Area (R x S) | 67.9" x 28.1" (1725 x 715mm) |
| Height (Q) | 7.1" (180mm) |

| | |
|---------------------------------|---|
| Drill Head: | |
| Spindle Taper | 4MT |
| Spindle Stroke | 9.84" (250mm) |
| Quill Diameter | 3.15" (80mm) |
| Number of Spindle Speeds | 2 |
| Spindle Speeds (rpm) | 44-1500 |
| Number of Feeds | 3 |
| Spindle Feed Rate (in(mm)/rev.) | 0.002"/(.05mm), 0.0035"/(.09mm), 0.006"/(.15mm) |
| Spindle Drive Motor (2-speed) | 3 hp (2.25 Kw) |
| Elevating Motor | 1 hp (.75 Kw) |
| Clamping Motor | 1 hp (.75 Kw) |
| Coolant Pump Motor | 1/8 hp (.10 Kw) |

| | |
|-------------------------------|---------------------|
| Dimensions and Weight: | |
| Max. Machine Height (F) | 109.5" (2780mm) |
| Base and Column Height (G) | 81.1" (2060mm) |
| Shipping Dim. | |
| Length | 80.1" (2035mm) |
| Width | 32.5" (862mm) |
| Height | 88.2" (2240mm) |
| Net Weight | 4,630 lbs. (2100kg) |
| Shipping Weight | 5,071 lbs. (2300kg) |

Dimensions:

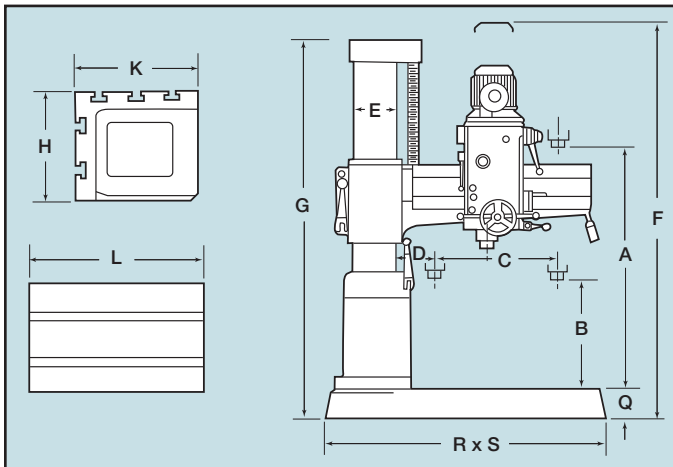

Capacities:

| Model | CL1230H |
|------------------|---------------|
| Capacity: | |
| Drilling | |
| In Steel | 1.65" (42mm) |
| In Cast Iron | 2.16" (55mm) |
| Tapping | |
| In Steel | 1" (25mm) |
| In Cast Iron | 1.38" (38mm) |
| Boring | |
| In Steel | 3.38" (86mm) |
| In Cast Iron | 4.72" (120mm) |