

# Clausing MAV Series Variable Speed Heavy-Duty Large Swing Lathes

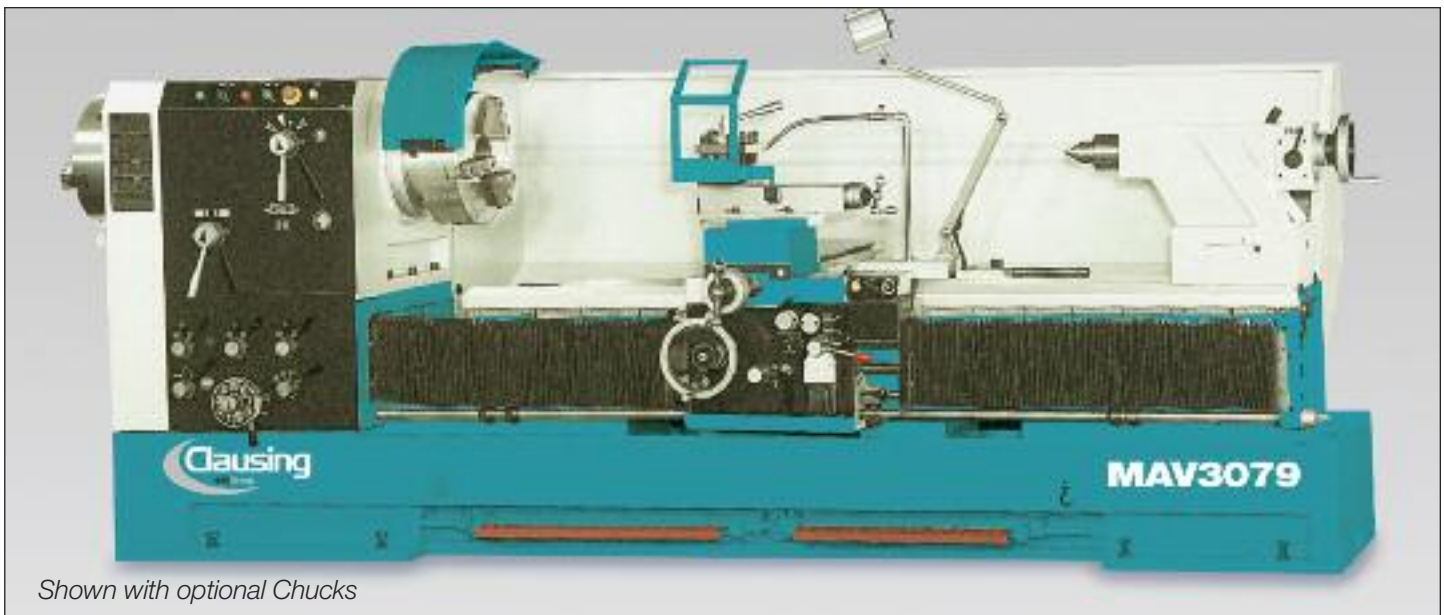

Shown with optional Chucks

**The Clausing MAV series large swing variable speed engine lathes are engineered to allow the accurate and efficient machining of large components. A wide range of optional accessories make these machines suitable for most industrial applications, including job shops, oil field, power utilities and ship building.**

## **Machine Standard Features:**

- Variable Spindle Speeds allow optimum cutting speed for a wide range of machining applications. Speed range from 14 to 1000 rpm
- 15 Hp Spindle Motor for exceptional machining power. Optional 20 Hp
- All gears are made from chromium molybdenum steel treated with cementation and precision ground for long-life and dependability.
- One-piece cast iron bed from the ways to floor provides a solid foundation to ensure maximum stability and rigidity under heavy machining operations.
- 18" Bed Width, Hardened and Ground, support the saddle and carriage assembly allowing superior positioning and repeatability accuracy.
- Turcite 'B' is fitted between saddle and bed to greatly reduce friction and stick-slip for smooth operation and superior surface finishes. The low friction Turcite 'B' also minimizes bed wear and extends the life of the machine.
- Immersing Style Lead Screw reduces abrasion.
- 4-way Rapid Traverse for positioning and set up.
- 4-way Power Feed for longitudinal, cross and compound feeds.
- Tailstock with 4.18" manual positioning for ease of setup and operation.
- 4.1" Spindle Bore supported with taper spindle bearings provides outstanding spindle performance and load carrying capabilities. Optional spindle bores available.
- Coolant system for tool life and part cooling.
- Automatic lubrication system to all guideways.
- Guarding powder coated for durability.
- Emergency brake pedal for safe operation.



Providing Solutions.

Phone: 916-638-7718 Fax: 916-638-2450

[www.scottmachinery.com](http://www.scottmachinery.com)

4700 Lang Ave, Suite D, McClellan, CA 95652

## Standard Equipment:

- Hardened and ground bed ways
- Hardened and ground gears
- Chuck guard with limit switch
- 15 Hp motor with inverter drive
- Variable spindle speeds, 14-1000 rpm, auto 3 range manual speed change
- 11" Capacity Steady Rest
- Follower Rest
- 4-way rapid traverse
- 4-way power feed
- 4-way, 8-position tool post
- 1.75" lead screw
- Lead screw cover
- Coolant system
- Automatic lubrication system
- Thread dial
- Manual tailstock w/ manual movement and anti slip lock
- Lockable main switch
- Halogen work light
- Leveling screws and pads
- Tools, tool box, operation manual

## Dimensions, Center Distance and Weight:

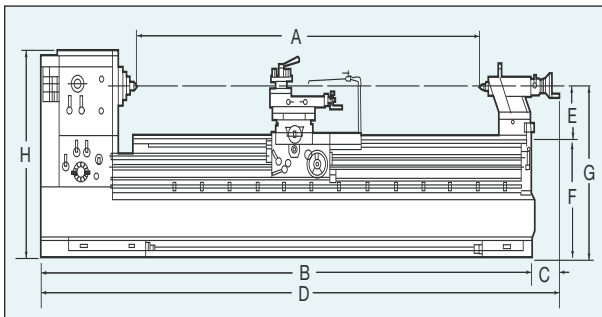

Model	E	F	G	H
MAV26	13.38" (340mm)	29.9" (760mm)	43.30" (1100mm)	55.1" (1400mm)
MAV30	15.35" (390mm)	29.9" (760mm)	45.27" (1150mm)	57.1" (1450mm)

Model	Width	Center A	B	C	D	Net Weight	Gross Weight
MAV26/3079	48.8" (1240mm)	79" (2000mm)	148" (3750mm)	5.9" (150mm)	154" (3900mm)	8,598 lbs. (3900kgs)	9,149 lbs. (4150kgs)
MAV26/30118	48.8" (1240mm)	118" (3000mm)	187" (4750mm)	5.9" (150mm)	193" (4900mm)	9,921 lbs. (4500kgs)	10,692 lbs. (4850kgs)
MAV26/30157	48.8" (1240mm)	157" (4000mm)	226" (5750mm)	5.9" (150mm)	232" (5900mm)	11,243 lbs. (5100kgs)	12,345 lbs. (5600kgs)
MAV26/30197	48.8" (1240mm)	196" (5000mm)	266" (6750mm)	5.9" (150mm)	272" (6900mm)	13,889 lbs. (6300kgs)	15,432 lbs. (7000kgs)
MAV26/30236	48.8" (1240mm)	236" (6000mm)	305" (7750mm)	5.9" (150mm)	311" (7900mm)	15,432 lbs. (7000kgs)	16,975 lbs. (7700kgs)
MAV26/30275	48.8" (1240mm)	275" (7000mm)	345" (8750mm)	5.9" (150mm)	350" (8900mm)	16,975 lbs. (7700kgs)	18,519 lbs. (8400kgs)
MAV26/30315	48.8" (1240mm)	315" (8000mm)	384" (9750mm)	5.9" (150mm)	390" (9900mm)	18,519 lbs. (8400kgs)	20,282 lbs. (9200kgs)

## Specifications:

Model	MAV26	MAV30
<b>Capacity</b>		
Swing over bed	26.7" (680mm)	30.7" (780mm)
Swing over cross slide	17.32" (440mm)	21.25" (540mm)
Swing in gap	38.12" (970mm)	42.12" (1070mm)
Gap (in front of faceplate)	19" (482mm)	19" (482mm)
<b>Headstock</b>		
Spindle nose	A2-11	A2-11
Spindle bore	4.13" (105mm)	4.13" (105mm)
Spindle taper		
Headstock	Variable Speed	Variable Speed
Speed Range 1	14-45 rpm	14-45 rpm
Speed Range 2	60-180 rpm	60-180 rpm
Speed Range 3	306-1000 rpm	306-1000 rpm
Min. spindle speed for full power	45 rpm	45 rpm
<b>Construction</b>		
Bed type	One Piece	One Piece
Bed width	18" (458mm)	18" (458mm)
Bed height over bed	13.38" (340mm)	15.35" (390mm)
Cross slide travel	15.35" (390mm)	15.38" (390mm)
Compound slide travel	9.5" (240mm)	9.5" (240mm)
Leadscrew diameter	1.77" (45mm)	1.77" (45mm)
<b>Thread and Feed Box</b>		
No. of longitudinal feeds	28	28
Range (in)	0.0019-0.027 in/rev	0.0019-0.027 in/rev
(mm)	0.05-0.7 mm/rev	0.05-0.7 mm/rev
No. of cross feeds	28	28
Range (in)	0.00019-0.1.38 in/rev	0.00019-0.1.38 in/rev
(mm)	0.025-0.35 mm/rev	0.025-0.35 mm/rev
No. of inch threads	36	36
Range	2-28 TPI	2-28 TPI
No. of metric threads	65	65
Range	0.8-14 mm	0.8-14 mm
No. of modular thread	22	22
Range	0.5-7 Mod	0.5-7 Mod
No. of diametral pitch threads	36	36
Range	4-56 DP	4-56 DP
<b>Tailstock</b>		
Quill diameter	8.26" (210mm)	8.26" (210mm)
Quill travel	4.13" (105mm)	4.13" (105mm)
Center taper	6MT	6MT
<b>Motors</b>		
Spindle motor	15 Hp (11Kw)	15 Hp (11Kw)
Rapid feed motor	1/4 Hp (.19Kw)	1/4 Hp (.19Kw)
Pump motor	1/8 Hp (.09Kw)	1/8 Hp (.09Kw)

(Specifications subject to change without notification)