

TECHNOLOGY

CREATIVITY

RELIABILITY

SMOOTH YOUR WAY TO SUCCESS

P r e c i s i o n S u r f a c e G r i n d e r



618M

816M/MR

1020AHD/SD

1230AHD/SD

1640AHD/SD

2040AHD/SD

S2460AHD/SD

Precision Surface

Manufactured to exact tolerance:

Parallelism:

**Longitudinal axis
0.0001"/12"**

**Cross axis
0.0002"/12"**

**Vertical axis
0.0004"/12"**

Squareness:

**X-Y-Z axis
0.0008"/12"**

**Flatness:
0.0002"/12"**

**Spindle runout:
0.00008"**

AUTOMATIC SURFACE GRINDER

"The rapid elevation motor helps me set up my jobs quickly and effortlessly. A real time saver."

"The centralized automatic lubrication system makes my maintenance work a breeze."

"Excellent tech-support. It's great talking to people who really know their stuff."



"Simple intuitive controls keep me on schedule making parts."

"Dependable. Keeps working day in and day out."

SGS-1230AHD

Grinder

.....Knowledge Driven Innovations
Since 1979

SADDLE TRAVERSE TYPE



SGS-1020AHD



SGS-1640AHD

MANUAL HANDFEED GRINDER



SGS-618M



SGS-816M / MR



*"Micro-downfeed
dial and rapid elevation
motor standard on
816MR models."*

Precision Surface

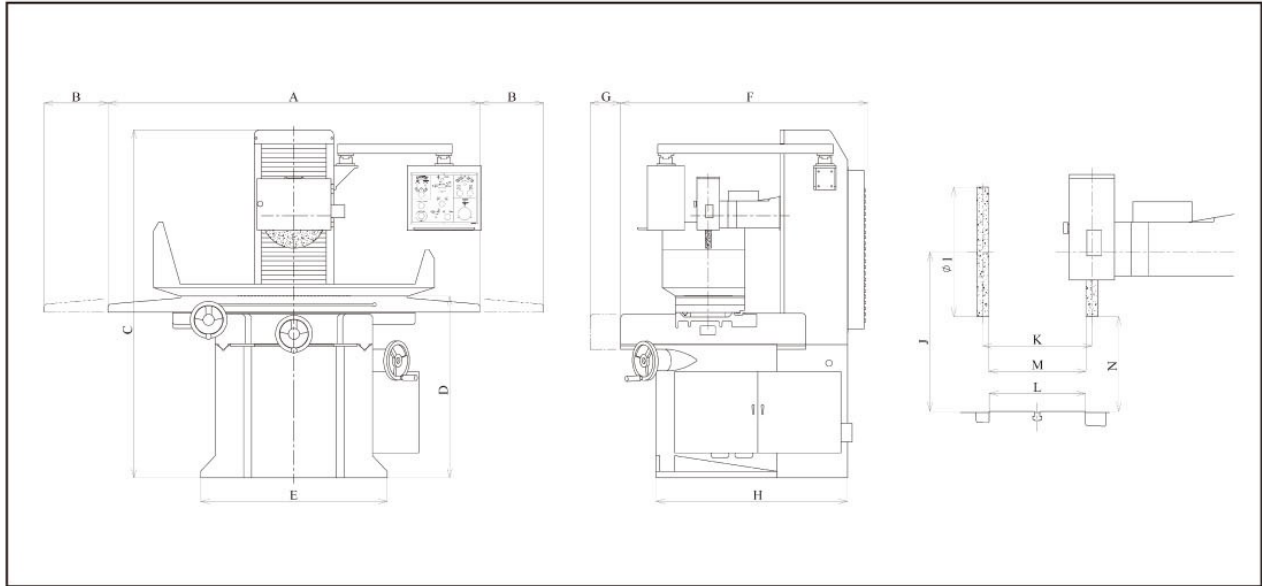

inch (mm)

	SGS-618 M	SGS-816 M / MR	SGS-1020 AHD / SD	SGS-1230 AHD/SD	SGS-1640 AHD/SD
A	49.6" (1260)	45.7" (1160)	65.4" (1660)	84.6" (2150)	114.2" (2900)
B	9.4" (240)	8.5" (215)	11.1" (282)	16.5" (420)	22.8" (580)
C	67.7" (1720)	67.7" (1720)	68.5" (1740)	74" (1880)	78.7" (2000)
D	36.3" (922)	36.3" (922)	35.3" (897)	36.1" (917)	37.7" (957)
E	24.3" (616)	24.3" (616)	35" (890)	39.8" (1010)	41.5" (1055)
F	33.5" (850)	35.4" (900)	40.2" (1020)	46.7" (1185)	63" (1600)
G	3.2" (82)	4.2" (107)	5.2" (132)	6.5" (166)	8.9" (225)
H	27.4" (697)	29.5" (750)	34.3" (870)	40.7" (1035)	56.1" (1425)
I	8.1" (205)	8.1" (205)	8.1" (205)	14" (355)	14" (355)
J	18.1" (460)	18.1" (460)	19.7" (500)	23.6" (600)	24.4" (620)
K	6.4" (163)	8.4" (213)	10.4" (263)	13.1" (332)	17.7" (450)
L	5.9" (150)	6.3" (160)	9.1" (230)	10.2" (260)	15.7" (400)
M	6" (152)	8" (203)	10" (254)	12" (304)	16" (406)
N	14.2" (360)	14.2" (360)	15.7" (400)	16.5" (420)	17.3" (440)

*We follow a policy of continuous improvement of all our products, and reserve the right to change specifications, or designs at any time without notice or obligation.

Grinder

.....Quality, Value, and Service
Since 1979

AUTO DOWN FEED

Models 1020AHD - 1640AHD

- Elevation motor for quick and easy grinding wheel rapid positioning.
- Surface grinding and Slot/Plunge grinding modes selectable.
- Easy to use direct reading slip ring sets the total amount of material to grind, with no need to calculate the number of passes required.
- A separate dial sets the down feed amount per pass between 0 and 0.001" in 0.0001" increments, which can be changed on the fly to accommodate grinding conditions without affecting the total grinding amount set in the previous step.
- Machine will spark out continuously at the end of the auto grinding cycle.
- This easy and intuitive system provides both control and flexibility to the operator, enabling the work to be done precisely and efficiently.

SPINDLE

Specially designed, dynamically balanced cartridge type spindle is totally enclosed and grease lubricated for the life of the spindle. Two pairs of ABEC-7 super precision angular contact bearings are matched and preloaded to enhance maximum grinding accuracy and reliability.



CONTROL SYSTEM

Simple and logical layout of electrical and electronic components with color and number coded electrical wiring provides reliable operation and easy troubleshooting or service. Control circuit operates on 24v AC for the safety of the operator.



ACCESSORIES



▲ Grinding Wheel and Wheel Flange



▲ Hydraulic System



▲ Wheel Balancing Base



▲ Magnetic Separator & Paper Filter Coolant System



▲ Wheel Balancing Arbor



▲ Table Diamond Dresser Base and Tips

Precision Surface

COLUMN TRAVERSE TYPE

20" x 40" through 34" x 120" capacity

- Dynamically balanced precision spindle with 3 pairs of precision ABEC-7 (P4) angular contact ball bearings for extra heavy cut
- Rapid elevation mode for quicker set-ups
- Selectable surface and slot grinding modes
- Digital counter for setting number of auto downfeed passes and spark out passes (AHD Type)
- Ten choices of downfeed increment settings from 0.0002" to 0.002" per pass (AHD Type)
- Automatic shut off of spindle and hydraulic system after completion of automatic downfeed cycle (AHD Type)
- V and flat longitudinal ways lined with Turcite-B Teflon linings for the smoothest movement and longevity
- Double V crossfeed ways for extra rigidity and accuracy over time
- Column traverse design allows for easy access to table to ease loading and unloading of large work pieces

SGS-2040AHD/SD

SGS-2448AHD

SGS-2480AHD

SGS-3488AHD

SGS-S2460AHD/SD

SGS-2460AHD

SGS-3468AHD

SGS-34120AHD



SGS-2040AHD

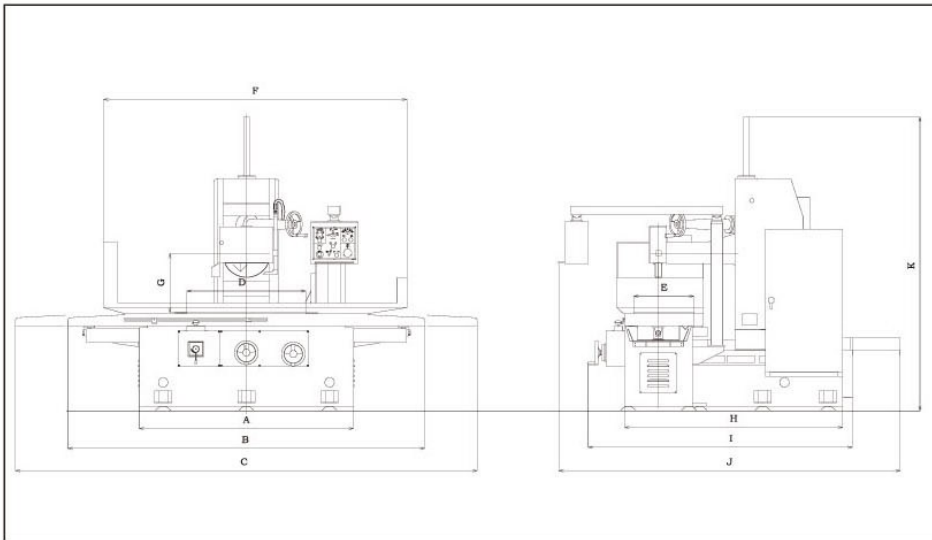

inch (mm)

	SGS-2040 AHD/SD	SGS-S2460 AHD/SD
A	70.8" (1800)	110.2" (2800)
B	118.1" (3000)	171.2" (4350)
C	163.7" (4160)	244" (6200)
D	41.7" (1060)	60" (1524)
E	20" (508)	23.9" (608)
F	100.3" (2550)	135.6" (3445)
G	23.6" (600)	23.6" (600)
H	72" (1830)	82.6" (2100)
I	87.4" (2220)	97.6" (2480)
J	109.4" (2780)	119.6" (3040)
K	95.2" (2420)	95.2" (2420)

*We follow a policy of continuous improvement of all our products, and reserve the right to change specifications, or design at any time without prior notice or obligation.

Grinder

.....Proven Reliability and Success
Since 1979

SD DOWNFEED MODEL FEATURES

- European CE certified electrics
- Proportional valve hydraulic system
- Proximity sensors for table reversal
- Table speed infinitely variable from 3.3'/minute to 83'/minute
- Easy electronic setting of crossfeed reversal positions on the control panel
- Servo motor downfeed system with close loop feedback
- Intuitive setting of total stock removal amount on automatic downfeed cycle with rough and fine feed and sparkout cycles
- Selectable surface and slot grinding modes
- Manual pulse generator Z axis handwheel and digital display of Z axis position allow for quicker setup of repetitive cycles

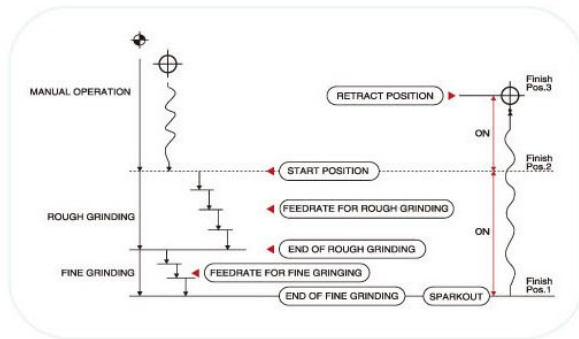

SGS-1020SD SGS-1230SD

SGS-1640SD SGS-2040SD



SGS-1020SD

DOUBLE COLUMN BRIDGE TYPE

47" x 59" through 70" x 472" capacity

SGS-1512AHD
SGS-2012AHD
SGS-2512AHD
SGS-3012AHD
SGS-4018AHD
SGS-5018AHD
SGS-6018AHD
SGS-7018AHD



SGS-3012AHD

SPECIFICATIONS	SGS-618M	SGS-816M/MR	SGS-1020AHD/SD	SGS-1230AHD/SD	SGS-1640AHD/SD	SGS-2040AHD/SD	SGS-S2460AHD/SD
Working Table Surface	5.9" x 18" (150 x 457)	6.3" x 16" (160 x 406)	9.1" x 19.7" (230 x 500)	10.2" x 29.5" (260 x 750)	15.7" x 39.4" (400 x 1000)	19.7" x 39.4" (500 x 1000)	23.6" x 59.1" (600 x 1500)
Max. Grinding Surface	6" x 18" (152 x 457)	8" x 16" (203 x 406)	10" x 20" (254 x 508)	12" x 30" (304 x 762)	16" x 40" (106 x 1016)	19.7" x 39.4" (500 x 1000)	23.6" x 59.1" (600 x 1500)
Max. Table Travel	18.9" (480)	16.9" (430)	22.2" (565)	33.1" (840)	45.7" (1160)	45.7" (1160)	65" (1650)
Max. Cross Travel	6.4" (163)	8.4" (213)	10.4" (263)	13.1" (332)	17.7" (450)	21.7" (550)	25.6" (650)
Distance between Table Surface and Spindle Center	18.1" (460)		19.7" (500)	23.6" (600)	24.4" (620)	23.6" (600)	
Table Speed	Manual		AHD-240~1000" / min (6-25 M/min) SD-80~1040" / min (2-26 M/min)			AHD-196~1000" / min (5-25 M/min) SD-80~1040" / min (2-26 M/min)	
Automatic Crossfeed of Saddle (60Hz)	Manual		0"~0.35" (0~9)		0"~0.47" (0~12)		0"~1" (0~25)
Vertical Handwheel (1 grad.)	0.0001" (0.002)	0.0005" (0.01)			0.00025" (0.005)		0.0001" (0.002)
Vertical Handwheel (1 rev)	0.05" (1)	0.1" (2)			0.05" (1)		0.02" (0.5)
Crossfeed Handwheel (1 grad)	0.001" (0.02)		0.005" (0.01)			0.001" (0.02)	
Crossfeed Handwheel (1 rev)	0.2" (4)			0.2" (5)			
Downfeed Micro Dial (1 grad)	N/A	MR-0.00005" (0.001)	AHD-0.0001" (0.002) SD-0.00005" (0.001)		AHD-0.0002" (0.005) SD-0.00005" (0.001)		
Downfeed Micro Dial (1 rev)	N/A	MR-0.00005" (0.001)	AHD-0.01" (0.2)			AHD-0.002" (0.05)	
Longitudinal Travel Adjustment From - To	Manual		2"~20" (50~508)	2"~30" (50~762)	2" ~ 40" (50~1016)	5.9" ~ 43.3" (150~1100)	5.9" ~ 63" (150~1600)
Crossfeed Travel Adjustment From - To	Manual		0"~10" (0~254)	0"~12" (0~304)	0"~16" (0~406)	0"~20" (0~510)	0"~24" (0~610)
Grinding Wheel (OD x T x ID)	8" x 0.5" x 1.25" (205 x 13 x 31.75)			14" x 1.25" x 5" (355 x 32 x 127)	14" x 2" x 5" (355 x 50 x 127)	16" x 2" x 5" (405 x 50 x 127)	
Spindle Speed 60Hz	3500RPM / 60Hz			1750RPM / 60Hz			
Spindle Motor	2HP x 2P			5HP x 4P	7.5HP x 4P	10HP x 4P	
Hydraulic Motor	Manual		AH-1HP x 6P AHD-2HP x 6P	2HP x 6P		5HP x 4P	
Crossfeed Motor	Manual		40W x 6P			1/4HP x 6P	
Downfeed Motor	N/A	MR-1/5HP x 6P	AHD-1/4HP x 6P SD-AC Servo Motor			AHD-1/2HP x 4P SD-AC Servo Motor	
Coolant Motor	1/8HP						
Dust Collector Motor	1/2HP x 2P				N/A		
Max. Load Capacity in Addition to Magnetic Chuck	220lbs (100kgs)		550lbs (250kgs)	836lbs (380kgs)	1430lbs (650kgs)	2200lbs (1000kgs)	2860lbs (1300kgs)
Net Weight	1540lbs (700kgs)	1430lbs (650kgs)	2970lbs (1350kgs)	4290lbs (1950kgs)	6600lbs (3000kgs)	9900lbs (4500kgs)	13200lbs (6000kgs)
Gross Weight	1870lbs (850kgs)	1760lbs (800kgs)	3520lbs (1600kgs)	4950lbs (2250kgs)	7480lbs (3400kgs)	11000lbs (5000kgs)	15400lbs (7000kgs)
Packing Dimensions	57.4" x 44.8" x 76.3" (1460 x 1140 x 1940)	53.5" x 44.8" x 76.3" (1360 x 1140 x 1940)	81.8" x 66.1" x 80.7" (2060 x 1680 x 2050)	88.9" x 68.5" x 87" (2260 x 1740 x 2210)	124" x 87" x 88.5" (3150 x 2210 x 2250)	132.6" x 89.7" x 87.4" (3370 x 2280 x 2220)	203.9" x 103.9" x 90.5" (5180 x 2640 x 2300)

Note: We reserve the right to modify the design, specifications, etc. to improve performance of machine without notice.

STANDARD ACCESSORIES

- Grinding wheel and wheel flange
- Wheel flange extractor
- Balancing base and arbor
- Table diamond dresser base and tips
- Leveling bolts and pads
- Toolbox with standard tools

OPTIONAL ACCESSORIES

- Permanent magnetic chuck
- Electric magnetic chuck and control
- Flood coolant system
- Dust-suction coolant system
- Paper filter and magnetic separator coolant unit
- Manual overhead parallel dresser
- Digital readout system
- Work light



KENT INDUSTRIAL (USA) INC.

1231 Edinger Avenue

Tustin, CA 92780

Tel: (714) 258-8526

Fax: (714) 258-8530

Toll Free: (800) KENT-USA

Internet: www.kentusa.com



Providing Solutions.

Phone: 916-638-7718 Fax: 916-638-2450

www.scottmachinery.com

4700 Lang Ave, Suite D, McClellan, CA 95652